



## Access Cabinet Base Blanking Plate Assembly

The open frame design of Cooper B-Line's Access Cabinet provides unrivalled cable entry capability thanks to its tubular frame. Whilst this scenario can be ideal for some applications other installations require the top and bottom cabinet apertures to be blanked off to control the thermal characteristics within the cabinet.

A new addition to the Access Cabinet System is this range of modular base blanking assemblies offering a variety of customer configurable options. Initially designed to compliment the 1000mm deep range of cabinets these assemblies are available to suit both 600mm and 800mm wide cabinet options.

By simply configuring the cabinet without the standard nylon skids the cabinet frame can sit directly onto the floor effectively sealing between the floor and the cabinet allowing the cabinet to be located over cut tile apertures. This solution removes the headache of trying to manage the sealing of the floor void at the tile level as the integrated brush strip cable entries effectively provide sealing around the cable bundles.

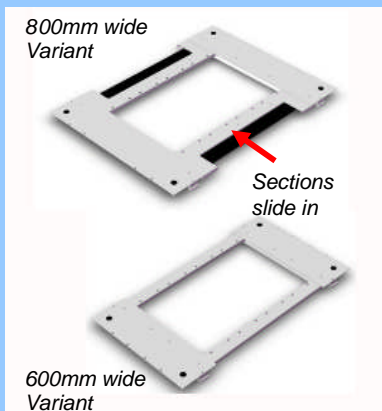
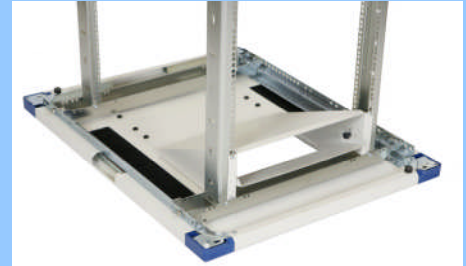

Each base blanking panel assembly comprises of a basic frame (shown left) onto which a number of customer configurable blanking options can be mounted. The base frames can be fitted with or without either the nylon skids or jacking feet and simply bolt to the underside of the base cabinet frame.

The 800mm wide variant provides a brush strip entry front to rear offering a cable aperture size of 500mm x 53mm. With the centre blanking panels removed the 800mm wide variant also offers the ability to slide the brush strip sections in board providing cabling clearance of 230mm to ease cabling installation.

Each base blanking panel frame has the option to mount four units of blanking with the blanking options being universal for either the 600mm or 800mm wide variants. Blanking options include the following;

- 1. Plain Blanking Panel** – These plain blanking panels fill one unit space and are fitted with quick fit ¼ turn tool less fixings allowing easy fitting. Simply align the panel with the corresponding holes in the base frame and secure in position using the captive fixings to provide an effective blanking solution.
- 2. Brush Strip Blanking Panel** – Like the plain blanking these units take up one unit space and also incorporate the same tool less ¼ turn fixings. The brush strip blanking panels offer a cabling aperture of 350mm x 64mm and can be fitted with the brush facing the front or rear of the cabinet. Indeed two panels can be mounted with the brush on the mating joint providing a cabling aperture of 350mm x 128mm.



## New Product Release

- 3. Air Deflector Cowl with Air Damper** – The deflector cowl has been designed to control the air flow from the floor void immediately under the cabinet. The cowl directs the air to the area in front of the 19-inch mounting angles ensuring that the cold air can effectively feed the cooling requirements for a normally aspirated piece of active equipment. The air damper incorporated in the unit allows the user to balance the air flow to the cabinet allowing fine tuning of groups of cabinets. This unit takes up two unit blanking spaces and mounts in the bottom 3U of the cabinet.
- 4. Scavenger Fan Tray Duct** – Designed to be used in conjunction with our 2U Scavenger Fan Tray this unit takes up the two front unit blanking spaces. Like the blanking panels the duct simply aligns with the corresponding holes in the base frame and secures in position using the captive tool less ¼ turn fixings.
- 5. 2U Scavenger Fan Tray** – The 2U Scavenger Fan Tray simply mounts into the bottom 2U of the cabinet and rests on the Scavenger Fan Tray Cowl. The Scavenger fan tray protrudes through the 19-inch aperture by approximately 130mm and is designed like the Air Deflector to pull cold air from the floor void immediately under the cabinet and feed the cold air to the area in front of the 19-inch mounting angles. Ideal for scenarios where the cabinet location suffers from too higher pressure (cabinet is too close to the CRAC unit) or insufficient pressure (cabinet is too far or isolated from the CRAC unit) the scavenger fan tray is capable of generating around 675m<sup>3</sup>/h air flow to the cabinet position.

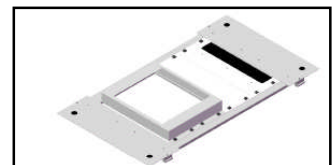
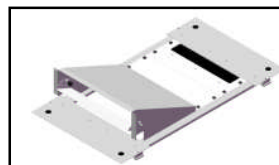
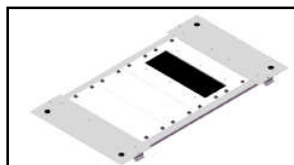
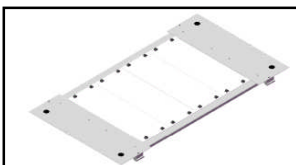
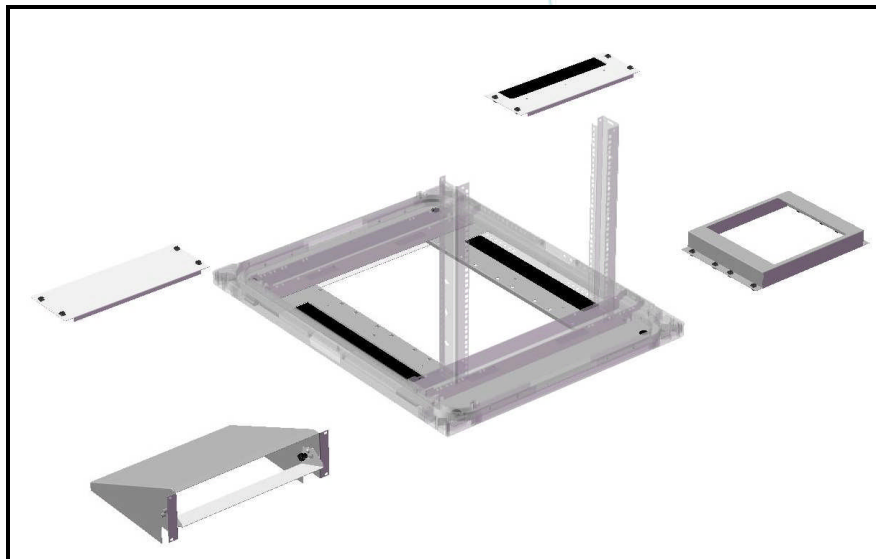
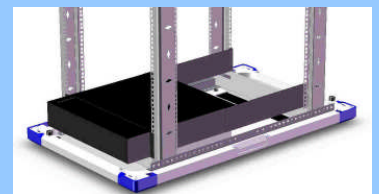
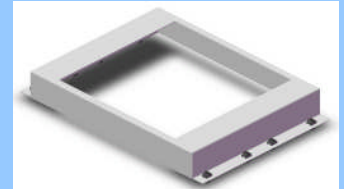
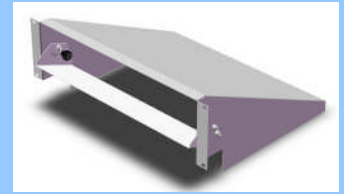

# New Product Release

## 600MM WIDE BASIC FRAME TECHNICAL SPECIFICATIONS

<b>Order Code</b>	ACBBF610B
<b>Material</b>	1.2mm Thick Mild Steel
<b>Finish</b>	Painted Black RAL 9005 <i>Items shown standard light grey finish for clarity only.</i>
<b>Supplied</b>	Factory fitted as standard* *Can be retro fitted to an empty cabinet.
	Each set comprises of <ul style="list-style-type: none"> <li>a. 2 x Front and rear sections.</li> <li>b. 2 x Front to rear sections.</li> <li>c. 1 x Fixing kit.</li> </ul>

## 800MM WIDE BASIC FRAME TECHNICAL SPECIFICATIONS

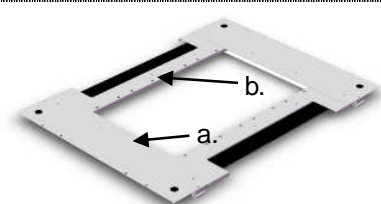
<b>Order Code</b>	ACBBF810B
<b>Material</b>	1.2mm Thick Mild Steel
<b>Brush Section</b>	55mm wide Black Nylon bistles on an Aluminium carrier
<b>Finish</b>	Painted Black RAL 9005 <i>Items show standard light grey finish for clarity only.</i>
<b>Supplied</b>	Factory fitted as standard* *Can be retro fitted to an empty cabinet.
	Each set comprises of <ul style="list-style-type: none"> <li>a. 2 x Front and rear sections fitted with front to rear panel support channels.</li> <li>b. 2 x Front to rear sections fitted with brush strips.</li> <li>c. 1 x Fixing kit.</li> </ul>

## PLAIN BLANKING PLATE TECHNICAL SPECIFICATIONS

<b>Order Code</b>	ACBBPPB	
<b>Material</b>	1.2mm Thick Mild Steel Panel	
<b>Fixings</b>	Black Polycarbonate Fixings Tool less ¼ turn captive fasteners.	
<b>Finish</b>	Painted Black RAL 9005 <i>Items shown standard light grey finish for clarity only.</i>	
<b>Supplied</b>	Factory fitted as standard	

# New Product Release

## BRUSH STRIP BLANKING PLATE TECHNICAL SPECIFICATIONS

<b>Order Code</b>	ACBBBBPB
<b>Material</b>	1.2mm Thick Mild Steel Panel
<b>Brush Section</b>	55mm wide Black Nylon bistles on an Aluminium carrier
<b>Fixings</b>	Black Polycarbonate Fixings Tool less ¼ turn captive fasteners.
<b>Finish</b>	Painted Black RAL 9005 <i>Items shown standard light grey finish for clarity only.</i>
<b>Supplied</b>	Factory fitted or retro fit option.



## DEFLECTOR ASSEMBLY TECHNICAL SPECIFICATIONS

<b>Order Code</b>	ACBBDAB
<b>Material</b>	1.2mm Thick Mild Steel Panel
<b>Fixings</b>	19-Inch Mounted
<b>Finish</b>	Painted Black RAL 9005 <i>Items shown standard light grey finish for clarity only.</i>
<b>Supplied</b>	Factory fitted or retro fit option.

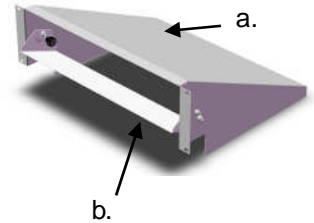

Each set comprises of;

- a. 3U 19-inch mounted deflector panels.
- b. Air damper assembly.
- c. Fixing pack.

## BRUSH STRIP BLANKING PLATE TECHNICAL SPECIFICATIONS

<b>Order Code</b>	ACBBSFDB
<b>Material</b>	1.2mm Thick Mild Steel Panel
<b>Fixings</b>	Black Polycarbonate Fixings Tool less ¼ turn captive fasteners.
<b>Finish</b>	Painted Black RAL 9005 <i>Items shown standard light grey finish for clarity only.</i>
<b>Supplied</b>	Factory fitted or retro fit option.

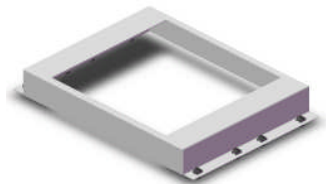

# New Product Release

## 2U SCAVENGER FAN TRAY TECHNICAL SPECIFICATION

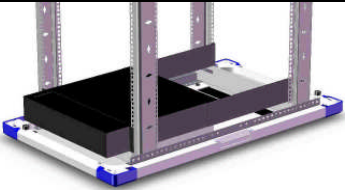
<b>Height</b>	2U (88.1mm)			
<b>Width</b>	482.6mm Wide (over mounting lugs) 432.6mm Wide (over plenum chamber)			
<b>Depth</b>	463.0mm			
<b>Protrusion Through 19-inch Mounting Facility Mounting Range</b>	100.0mm EIA 310D 19-inch Compliant 420.0mm Min 675.0mm Max			
<b>Unit Weight</b>	8.1kg			
<b>Material</b>	1.5mm Mild Steel			
<b>Finish</b>	Painted Black RAL9005			
<b>Power Indicator</b>	LED lit green when power is present.			
<b>Lead Type</b>	Supplied with IEC 320 (10amp) to UK 3-Pin (BS1363) lead.			
<b>Warranty</b>	12 Months			
	Description	Electrical Supply	Order Code	Air Flow Characteristics
	2U Scavenger Fan Tray Assembly	220v A/C 50Hz	RMHPFU230	675m³/Hour
		110v A/C 60Hz	RMHPFU120	695m³/Hour
<b>Compliance</b>	<b>WEEE Directive. RoHS Compliant CE Approved</b>			

## Part Number Order Codes & Descriptions

Part Number	Description	Lead Time	Finish	Weight (kg)
ACBBF610B	Access Cabinet Base Blanking Frame 600mm wide x 1000mm deep	11 – 15 Working Days	Black	3.7kg
ACBBF810B	Access Cabinet Base Blanking Frame 600mm wide x 1000mm deep	11 – 15 Working Days	Black	7.0kg
ACBBPPB	Access Cabinet Base Blanking Plain Panel	11 – 15 Working Days	Black	0.7kg
ACBBPPB	Access Cabinet Base Blanking Brush Strip Panel	11 – 15 Working Days	Black	0.9kg
ACBBDAB	Access Cabinet Base Blanking Deflector Assembly	11 – 15 Working Days	Black	3.2kg
ACBBSFDB	Access Cabinet Base Blanking Scavenger Fan Duct	11 – 15 Working Days	Black	1.9kg
RMHPFU230	2U Scavenger Fan Tray Assembly - 220v A/C 50Hz	5 – 7 Working Days	Black	8.1kg
RMHPFU120	2U Scavenger Fan Tray Assembly - 110v A/C 60Hz	5 – 7 Working Days	Black	8.1kg

Specifications subject to change without notice. For further details please contact our customer services team.